

WILD COUNTRY SLINGS

GENERAL INFORMATION

These instructions must be read and understood before this equipment is used, please retain this information for future reference.

Under European Union regulations (Directive 89/686/EEC) Climbing and Mountaineering Equipment are classed as Personal Protective Equipment (PPE) and as such we are required to supply the following instructions. Adhere strictly to the following advice and recommendations, if in doubt please contact Wild Country Ltd..

The information in these instructions is not exhaustive and cannot be substituted for comprehensive instruction by trained and competent persons.

This product should only be used by trained and competent persons or the user should be under the supervision of a trained and competent person.

Climbing and mountaineering are hazardous. Even correct selection, maintenance and use of correct equipment cannot eliminate the potential for danger, serious injury or death.

It is the users responsibility at all times to ensure that he or she understands the correct and safe use of any equipment supplied by Wild Country Ltd., uses it only for the purposes for which it is designed and practices all proper safety procedures. The manufacturer or supplier will not accept any responsibility for damage, injury or death resulting from misuse.

USE

This product complies with EN 566 and is designed as a Sling for climbing and mountaineering purposes for use in normal climatic conditions and in temperatures not exceeding 50°C.

This product should be used as instructed. It may be used in conjunction with any appropriate item of PPE covered by the aforementioned directive of suitable specification with due consideration to the limitations of each individual piece of equipment and of the belay system as a whole. No alterations or markings should be made to it.

The safety that this product provides depends upon its strength, the quality of the rock anchorage used and the integrity of the belay point. The strength will be reduced through age and general wear and tear dependant upon the amount of use to which it is put.

The following will cause a further reduction in strength:

- high impact load/fall arrest
- corrosion
- internal/external abrasion of textile components caused by grit penetration and rock abrasion
- cuts in textile components
- prolonged exposure of textile components to ultra violet radiation
- placement and/or loading over tight radii
- sharp edges of rock or equipment

The security provided by this product is totally dependant on the skill of the user. The user should have the experience to assess the following:

- The suitability of this product for its intended use.
- The reliability of the rock anchor or belay point.
- The expected direction of loading.
- That there are no edges or projections that could damage the product when under load.

See maintenance and obsolescence for more details.

Be aware that this equipment can be damaged in a fall and consequently should always be examined for defects before reuse. If this equipment exhibits signs of wear or defect or if there is any doubt about its serviceability, replace it. It is recommended that any equipment involved in a serious fall should be replaced. Where practical a history of use and inspection record should be kept.

Wearing a climbing helmet will help protect your head from injury if you fall.

When using belay techniques we recommend the use of appropriate gloves.

Foresee and take appropriate action in situations where rescue may be required.

TEMPERATURE

Always keep products made wholly or partially from textile elements below 50°C as the performance of the nylon /Dyneema from which they are made may be affected at temperatures above this. Tests down to -40°C show no permanent change in the performance of this material although nylon /Dyneema may stiffen while at temperatures below 0°C.

SEA WATER

It is essential that this equipment is cleaned as soon as is practical after exposure to sea water or any saline environment (e.g. when used on sea cliffs).

CHEMICALS AND CORROSIVE REAGENTS

Avoid all contact with chemical reagents as they will affect the performance of this product (e.g. vehicle battery acid, bleach etc.). Discard this product immediately if contact has or is suspected to have occurred (the product may be permanently weakened without showing any signs).

MAINTENANCE

This product is not user maintainable with the exception of cleaning and lubrication (where relevant).

CLEANING

First rinse the product in clean cold water of domestic supply quality. If still soiled rinse in warm water (maximum temperature 40°C) with pure soap. Thoroughly rinse and dry naturally in a warm ventilated room away from direct heat.

STORAGE

After any necessary cleaning store unpacked in a cool, dark, dry, ventilated place away from sharp edges, pressure, corrosives or any possible causes of damage. Wet equipment should first be allowed to dry as detailed above.

OBSOLESCENCE

This product will deteriorate over time in the course of normal use and because of this we are required by directive 89/686/EEC to give an obsolescence date. It is difficult to be precise but a conservative estimate for this product is that it has a lifespan of 10 years from date of first use for metal components or 5 years from date of first use or 10 years from date of first storage for textile components, however, please note that the following factors will further reduce the safe working life:

Metal Components (where relevant): normal use, exposure to chemical reagents, heat contamination, high impact load or failure to maintain (clean/lubricate) as recommended. See above (use)

Textile Components: most textile materials used in safety equipment are known to degrade gradually with time even when stored in ideal conditions. Additionally normal use, rope burn, exposure to chemical reagents, exposure to elevated temperatures, high impact load, prolonged exposure to UV light, including sunlight, abrasion, cuts or failure to maintain (clean) as recommended will cause further reductions in strength. See above (use).

On textile elements (where fitted) check stitching for broken, cut, pulled or worn threads and inspect buckles (where fitted) for cracks, distortion, burrs or corrosion.

In addition to the normal inspection required before use this product should be thoroughly examined at least once every three months by a competent person. If any defects are found as detailed above or are suspected this product should be withdrawn from use immediately.

WARNING

The safe working life of this product may be as little as one use in extreme circumstances.

TRANSPORTATION

Care should be taken to protect this product against risks such as those detailed under obsolescence. It is recommended that a rucksack or other suitable bag or container is used during transport.

MARKINGS

The CE mark must be affixed to all Personal Protective Equipment (PPE) used for climbing and mountaineering in accordance with European Union Directive 89/686/EEC. The CE mark has been affixed to this product following type examination and testing by an accredited notified body to the relevant European Standard. The notified body for Wild Country products is:

SGS (UK) Ltd.,
(notified body No. 0120),
202b Worle Parkway,
Weston Super Mare,
BS22 6WA, UK.

The following information appears on the woven label attached to this product:

0120CE
notified body number, CE mark,

Wild Country Ltd.:
name of manufacturer/supplier.

Made in UK:
country of origin.

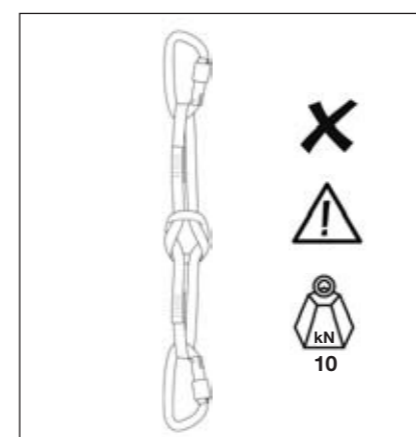
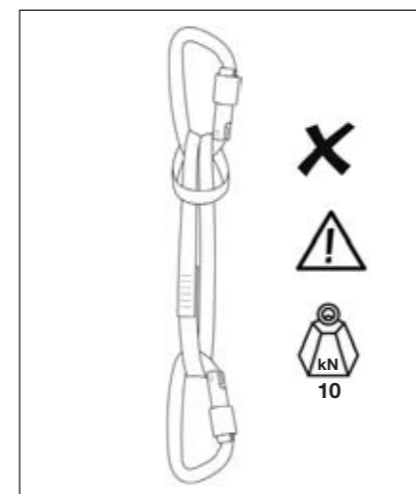
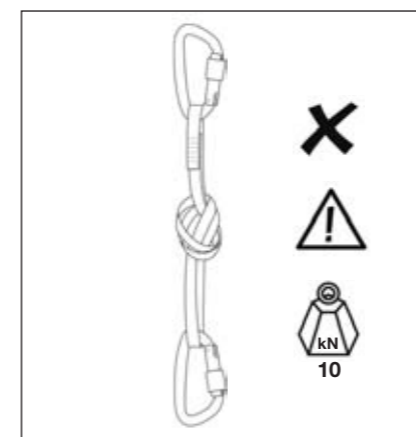
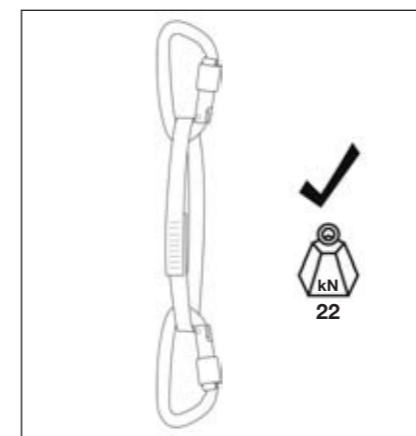

Three digit code:
batch/date code 'ABC'.

'A' First letter indicates year of manufacture e.g. A =Year 2000, B = Year 2001 etc.

'B' Second letter indicates manufacturer Wild Country internal reference.

'C' Third letter indicates month of manufacture e.g. A = January, B = February etc.

EN566:

the European standard to which this product conforms.

In addition the rated strength(s) are marked in accordance with the applicable reference standard as required.

Wild Country Ltd reserves the right to modify without notice the design and specifications of products described in these instructions. All weights, dimensions and sizing specifications where quoted are nominal.

Wild Country Ltd.,
Meverill Road, Tideswell, Derbyshire,
SK17 8PY England

Tel: +44 (0) 1298 871010
Fax: +44 (0) 1298 872077

E-mail: info@wildcountry.co.uk
Web Site: www.wildcountry.co.uk

CERTIFICATE NO
93/2678
96/7545



UIAA

0120 CE

F088a/QA/3/FEB10/V5129

**WILD
COUNTRY**

Slings/Sangles

